

## LASER BEAM DELIVERY AT ELI-NP

D. URSESCU<sup>1,\*</sup>, G. CHÉRIAUX<sup>2</sup>, P. AUDEBERT<sup>2</sup>, M. KALASHNIKOV<sup>3</sup>, T. TONCIAN<sup>4</sup>,  
M. CERCHEZ<sup>4</sup>, M. KALUZA<sup>5</sup>, G. PAULUS<sup>5</sup>, G. PRIEBE<sup>6</sup>, R. DABU<sup>1</sup>, M.O. CERNAIANU<sup>1</sup>,  
M. DINESCU<sup>7</sup>, T. ASAVEI<sup>1</sup>, I. DANCUS<sup>1</sup>, L. NEAGU<sup>1</sup>, A. BOIANU<sup>1</sup>, C. HOOKER<sup>8</sup>,  
C. BARTY<sup>9</sup>, C. HAEFNER<sup>9</sup>

<sup>1</sup> ELI-NP, "Horia Hulubei" National Institute for Physics and Nuclear Engineering,  
30 Reactorului Street, RO-077125, Bucharest-Magurele, Romania

<sup>2</sup> Laboratoire pour l'Utilisation des Lasers Intenses, École Polytechnique, Route de Saclay,  
91128 Palaiseau cedex, France

<sup>3</sup> Max Born Institut, Max-Born-Straße, 12489 Berlin, Germany

<sup>4</sup> Heinrich Heine Universität, Moorenstraße 5, 40225 Düsseldorf, Germany

<sup>5</sup> Friedrich-Schiller-Universität, Fürstengraben 1, 07743 Jena, Germany

<sup>6</sup> European XFEL, Albert-Einstein-Ring 19, 22761 Hamburg, Germany

<sup>7</sup> National Institute for Lasers, Plasma and Radiation Physics, INFLPR, Atomistilor 409, 077125  
Magurele, Romania

<sup>8</sup> Central Laser Facility, STFC Rutherford Appleton Laboratory, Harwell Oxford, OX11 0QX,  
U.K.

<sup>9</sup> Lawrence Livermore National Laboratory, Livermore, 7000 East Ave, Livermore, CA 94550,  
United States

\* Corresponding author *E-mail*: daniel.ursescu@eli-np.ro

*Abstract.* The Laser Beam Delivery (LBD) system technical design report covers the interface between the High Power Laser System (HPLS) and the experiments, together with the pulse quality management. The laser transport part of the LBD has a number of subsystems as follows: the beam transport lines for the six main outputs of HPLS, the additional short and long pulses and the synchronization system including the timing of the laser pulses with the Gamma Beam System (GBS) and the experiments on femtosecond timescale. Pulse quality management, discussed further here, consist in the generation and delivery of multiple HPLS pulses, coherent combining of the HPLS arms, laser pulse diagnostics on target, laser beam dumps, shutters and output energy adaption.

*Key words:* ultra-short laser pulses, ultra-intense laser pulses, extreme light

## 1. INTRODUCTION

Extreme Light Infrastructure is a pan European distributed facility, based on three pillars under construction, dedicated to the production of extreme fields with the lasers and subsequent research. The Extreme Light Infrastructure – Nuclear Physics (ELI-NP) facility, to be built in Magurele, Romania, shall host a dual arm High Power Laser System (HPLS) with a maximum output peak power for each arm corresponding to 10 PW.

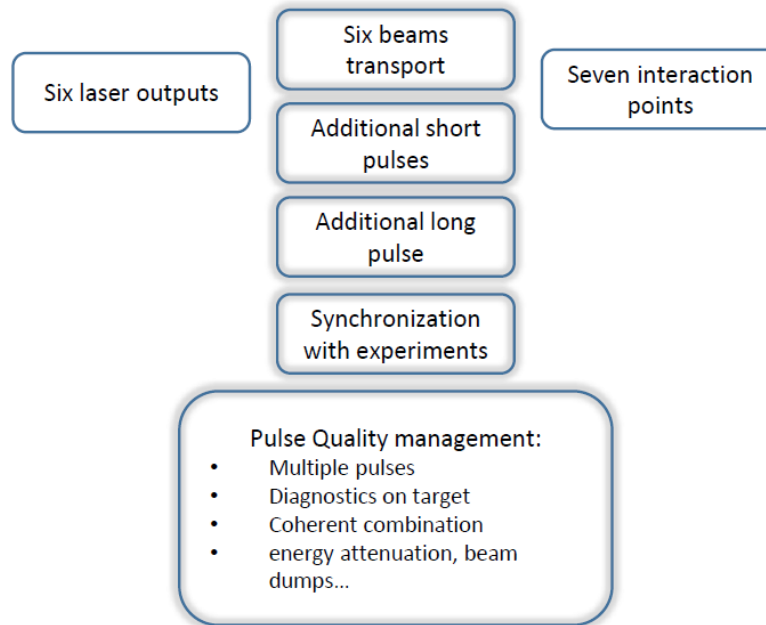

Fig. 1 – Main modules of the LBD system.

The high power laser system (HPLS) of the Extreme Light Infrastructure consists of six optical outputs: two 0.1 PW outputs running at 10 Hz repetition rate, two 1 PW outputs running at 1 Hz and two 10 PW outputs running at 1 shot per minute. The Laser Beam Delivery (LBD) system interfaces the high power laser system (HPLS), the Nuclear Physics facility and the experiments and comprise both, the optical output delivery including laser pulse adaption on demand and the electronic synchronization, in particular of the HPLS with the Compton-based Gamma Beam System (GBS) and with the experiments, as well as the pulse quality management. The main modules of the LBD are illustrated in fig. 1 below.

The LBD can be also seen as having two parts: one consists in the systems that deliver the optical pulses and electronics signals from the laser side to the facility (**Pulses transport - PT**) while the other part takes care on the quality of the service (**Pulses quality - PQ**).

Several technologies are considered to be implemented on the pulse transport side. Beam transport systems will deliver the laser pulses from the two 10 PW outputs to the experimental areas E1, E6 and E7. E1 experimental area will house Laser Driven Nuclear Physics experiments, E6 area will be dedicated to High Field QED experiments, while E7 area is designated to the combined Laser – Gamma experiments. Additional laser pulses will enable specific experiments, as follows: a long pulse will be delivered at E1, as a replacement for one compressed

pulse and an additional short pulse will be generated for probing ultrafast phenomena at E6 experimental area. Synchronization signals to GBS, E1, E4, E5, E6 and E7 shall be provided. E4 and E5 bunker areas will host the intermediate outputs of the two HPLS arms with 100 TW, respectively two with 1 PW laser beams to the interaction chambers from these experimental areas.

On the pulse quality side, alignment procedures and pulse monitoring and control technologies have to be developed. They include multiple laser pulses production in the amplification chain, pulse diagnostics on target, pulses synchronization and coherent combination, laser beam dumps, shutters and energy attenuation control.

## 2. PHYSICS CASES AND LBD REQUIREMENTS

The present Technical Design Report (TDR) for Laser Beam Delivery (LBD) constitutes an interface between the HPLS system to be delivered under contractual terms by Thales consortium and the experimental areas. In this regard, the TDR LBD addresses the specific engineering challenges providing the experiments with advantageous laser beams, offering world class science possibilities and it is designed with modularity and scalability in mind.

Some specific laser pulse delivery issues have to be properly addressed on the experiment side. As an example, back reflection isolation has to be considered for all the interactions with solid targets at close to normal incidence angles.

Also, the beam transportation involves for all the experiments the presence of alignment lasers. Systems for in situ monitoring of the focal spot on target, with specific features for solid targets, for ultra-thin films and for gaseous targets are also required.

The laser pulse conditioning is requested in general in most of the laser driven experiments. Hence diagnostics of the laser pulses in the vicinity of the target is implicitly considered.

From the experiments involving HPLS as a source, presented in [1-4], an extended list of requests was collected, as presented in the following sections. The control system requirements for the experiments are described elsewhere [5].

### 2.1. TDR1: LASER-DRIVEN NUCLEAR PHYSICS

TDR1 proposes accelerated ions in the Radiation Pressure Acceleration (RPA) regime in order to reach the experimental acceleration of heavy ions such as Th. As a consequence, high temporal contrast and circular polarization are needed.

As the intended intensities in the focus are of the order of  $10^{23}$  W/cm<sup>2</sup>, adaptive optics and short focal distances shall be implemented.

In addition, a PW beam from E5 for pump probe experiments is required. The synchronization shall be also at the 10 fs resolution range and the optical paths of the beams shall be balanced.

A long laser pulse, in the range of one ns with energy in the range of 100 J and above is useful for plasma production.

Finally, the laser diagnostics on target consisting standard ultra-short laser pulse measurement devices shall be in place.

The table 1 presents several options of gradual development of the experimental area in order to provide the laser driven nuclear physics program with extended versatility. The targeted design for E1 at the end of 2018 is the solution involving two 10 PW pulses in E1. Plasma mirror is considered after the focusing optics, for debris mitigation while the circular polarization is essential for the RPA mechanism implementation.

Solution		Physics Case
<b>Requirements for E1</b>		
<i>Preliminary solution</i>	10 PW with focus > 3 $\mu$ m with plasma mirror with circular polarization high contrast	A split of primary beam inside Target Chamber may be used to create the second beam when requested by experiments
<i>Two beams solution</i>	10 PW as above + 1 PW (or 20 J uncompressed) w/o plasma mirror direction: $\sim 90^\circ$ or other	10 PW for acceleration and 20 J for target-plasma creations or focusing devices charging
<i>Two full beams solution</i>	2 x 10 PW as above (second beam at smallest possible angle)	Requested by fission fusion experiments Other experiments need second beam $\sim 90^\circ$
<b>Requirements for E5</b>		
Two beams solution	1 PW with minim focus with plasma mirror with circular polarization + 1 PW (or 20 J uncompressed) without plasma mirror direction: $\sim 90^\circ$ or other	1 PW for acceleration and 20 J for plasma-target generation or focusing devices charging

Table 1. Main requirements for the experimental areas E1 and E5, as derived from Laser driven nuclear physics TDR.

## 2.2. TDR2: STRONG FIELD QED

Within TDR2, electron behavior in ultra-intense laser fields will be studied. On one side, the tightly focused beams on solid targets will be used for electron positron pairs creation studies. In this case, the requested specifications are similar to the ones for the laser driven nuclear physics experiments, namely, high temporal contrast and circular polarization are needed. As the intended intensities in the focus are of the order of  $10^{23}$  W/cm<sup>2</sup>, adaptive optics and short focal distances shall be implemented.

On the other hand, Compton backscattering using ultra-relativistic electrons experiments and also radiation reaction experiments are involving a setup with long focal length optics, corresponding to an f-number of at least 10. Polarization of the laser is not an issue in this case but there is a request for a second 10 PW laser pulse with synchronization below 10 fs level.

Additional probe pulse with duration below 7 fs is needed for probing the plasma density in the gas jet under laser irradiation.

Required laser pulse parameters and control are summarized in the table below:

<b>Laser pulse parameters requested</b>	
1	Highest possible intensity larger than $10^{23}$ W/cm <sup>2</sup> implying short focal length F# of about 2 (or smaller) off-axis parabolas. Off-axis parabolas should be mounted (for example with the incident beam onto the parabola coming from outside the horizontal plane) to provide greatest possible access around the target for diagnostics.
2	Two 10 PW beams combined on-target to maximise the intensity. Several different geometries may be required; Coherent addition and overlapping of the pulses; Phase front tilt control is needed. The phase front of the combined beams needs to be investigated, as a longer term objective to maximise focused intensity.
3	Polarisation control is required, including the ability to switch between linear and circular polarisation.
4	Ultra-high intensity contrast is needed, <i>e.g.</i> larger than $10^{13}$ at ns and larger than $10^{12}$ at ps time scale. This is required for solid targets and thin foil experiments. Plasma mirror may be required to achieve this, which in turn requires research and development effort.
5	Temporal shaping and control of rising edge of the laser pulse.
6	Spatial shaping and control of focal spot distribution. Possible use of adaptive optics to maximise the encircled energy within the focal spot.

7	Laser beam transport and relay to the appropriate target areas – It is envisaged that area E6 will be used for single 10 PW and/or area E7 for dual 10 PW experiments on this topic.
8	Debris mitigation is a potential issue due to short focal length of the focusing optics and the fact that there will potentially be up to 1500 laser shots per week available. One example solution is suitable pellicles with minimum wavefront distortion. Interchangeable optics are required in case of damage to minimise downtime (due to the long lead time for engineering a delivery of large focusing optics).
<b>Laser diagnostics includes:</b>	
1	Intensity-temporal contrast measurement, especially on the rising edge of the laser pulse; FROG – frequency resolved optical gating diagnostic.
2	Measurement of the laser focal spot energy distribution and the phase front.
3	Measurement of the degree of temporal overlap (via autocorrelation or balanced cross correlator) and spatial overlap of the two 10 PW foci in the target plane.
4	Synchronised optical probe to characterise the density gradients at the target front surface.
5	Near and far field monitoring of the laser beams.
6	Spectrometers, power meters.

Table 2. Main requirements for the experimental area E6

### 2.3. TDR3: COMBINED LASER-GAMMA EXPERIMENTS

For the combined laser-gamma experiments described in TDR3, the synchronization of the HPLS laser with the laser that drive the Compton backscattering process is mandatory. The resolution for the synchronization is in the range of a fraction from the electron bunch length, namely, few hundreds of fs. Moreover, coherent combination of the two laser pulses is requested on the long run, in order to provide the highest possible intensity on target.

There is also a specific request for E4 and E5 experimental areas to perform studies related to dark energy. The requirement is to have the laser beams synchronously on the target in both experimental areas.

The laser diagnostics on target involves standard ultra-short laser pulse measurement devices.

#### 2.4. TDR4: IRRADIATED MATERIALS SCIENCE

In the TDR4 case, the laser pulses combined with various radiation types are requested, involving electrons, gamma, protons, neutrons and positrons for material science and biology related experiments. The delay between the pulses shall be controlled over up to 10 ns with sub 10 fs resolution. The technologies required for the 0.1 PW and for the 1 PW outputs are circular polarization with polarization ellipticity control, a plasma mirror for temporal contrast enhancement as well as adaptive optics. However, no relay imaging is needed, due to the presence of the HPLS outputs directly in the experimental caves E4 and E5, respectively.

The laser diagnostics on target involves standard ultra-short laser pulse measurement devices.

### 3. TECHNICAL PROPOSAL

This section covers general aspects and an introduction in the technologies of interest to ELI-NP LBD and the intended implementation mode.

#### 3.1 BEAM TRANSPORT LINES FROM THE SIX MAIN OUTPUTS OF HPLS

The beam transport systems for 0.1 PW and 1 PW outputs to the E4 and E5 experimental areas are part of the HPLS laser contract. They will be delivered by Thales Optronique SA to the corresponding experimental areas E4 and E5.

As a consequence, the focus is on the 10 PW outputs to the experiments.

	<b>Main technologies:</b>	<b>Impacts</b>
1	Relay imaging	Pointing stability
2	Plasma mirror	Temporal contrast
3	Polarization control	Process induced on target
4	Adaptive optics	Quality of focus
5	Back reflection Isolation	Laser existence
6	Focusing optics	Experiment

Table 3. Main technologies for beam transport system.

The six technologies to be implemented, as shown in the above table, are related to the specific beam parameters and properties requested in the experimental areas, at the interaction point.

A possible layout of the beam transportation for the HPLS 10 PW outputs is depicted in fig. 2. It includes simple design for all the above mentioned

technologies, for both arms of HPLS. Detailed description of each module follows in subsections.

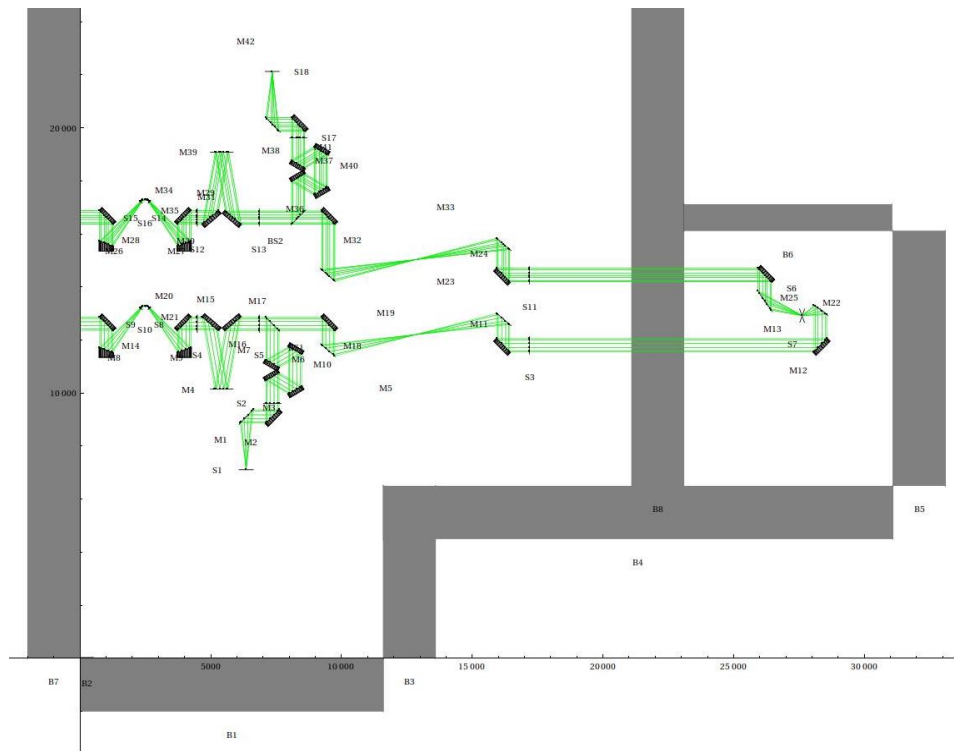

Fig. 2 – Preliminary version of the 10 PW transport lines (see supplementary material). Each arm of the beam transport includes a plasma mirror system, an adaptive optics system, a system to generate circular polarization and relay imaging system as further discussed in the text and represented in figures 3,5,6,7 and 8.



### 3.1.1 Relay imaging

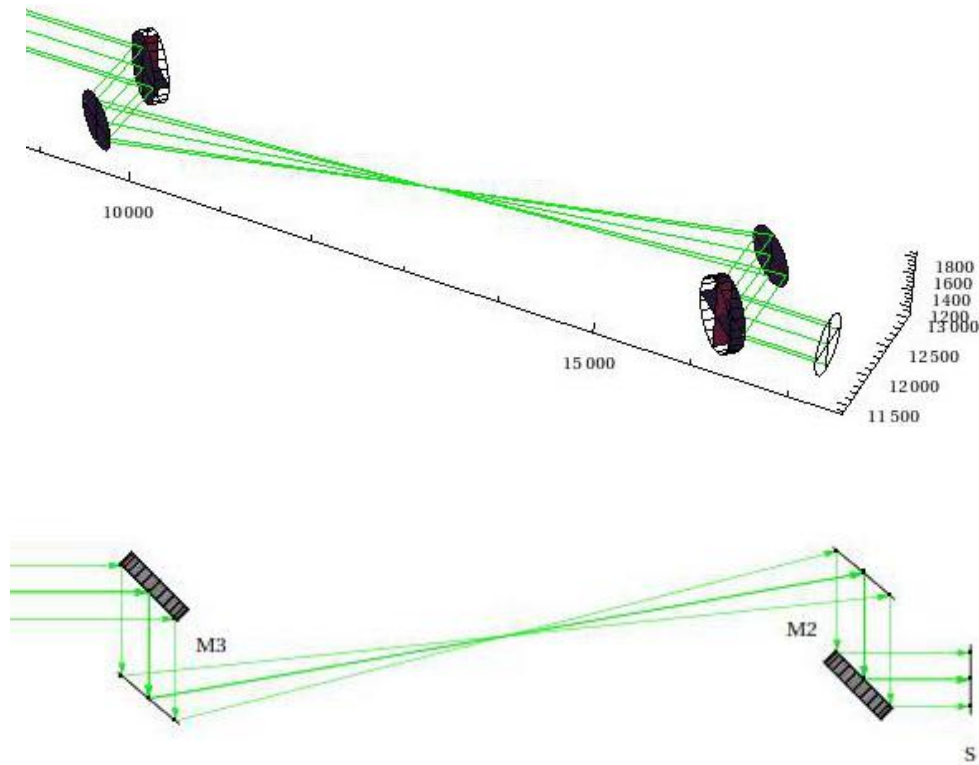

Fig. 3 – Relay imaging system, a 3D view and a top view. Two flat and two parabolic mirrors are involved.

Propagation distances after compression of the 10 PW beam lines are in the range of several tens of meters. As a consequence the effect of the beam spatial phase on the propagation can lead to different modifications of the laser beam. The energy distribution could develop some high spatial frequencies modulations (hot spots) which can damage the transport optics; some spatio-spectral coupling can lead to local changes of the pulse duration and the beam pointing stability can be decreased.

A solution to avoid these drawbacks of the implementation is to install some relay imaging system into the beam transport path as illustrated in fig. 3. Nevertheless such a system is complex for short pulse lasers. An achromatic and stigmatic optical lay-out has to be used.

The solution will be based on reflective optics such as off-axis parabolas. There are several possible configurations; one approach as implemented on Apollon-10P within the amplifier stages is using parabolas at 45° incidence angle on a Z configuration.

In terms of pros and contras:

Pro	Contra
<ul style="list-style-type: none"> <li>- Achromatic</li> <li>- Astigmatic</li> </ul>	<ul style="list-style-type: none"> <li>- As the system is after the compression, large optics will have to be used</li> <li>- High cost for the parabolas</li> <li>- Sensitivity of beam alignment</li> <li>- Large vacuum tubes</li> </ul>

Table 4. Advantages and disadvantages related to relay imaging implementation.

Analysis of the impact of the propagation distances on the laser pulses has first to be done in order to quantify the modifications. But as a general rule, the larger deflection angles of the parabolic mirrors are associated with larger distortions of the beams.

### 3.1.2. Plasma mirror technology

Experiments involving the intense ultrashort pulsed lasers strongly requires a high pulse contrast (ratio between the peak intensity and the intensity of amplified spontaneous emission, ASE, and existing pre-pulses) greater than  $10^9$ . Hence, the research in the field of contrast enhancement has been intensified during the last years. Two approaches have been successfully applied to advanced state of the art laser systems: Improvement of the laser chain itself, as well as cleaning the pulses after compression. The former uses double CPA [6] together with cross-polarized wave generation (XPW) [7] or optical parametric CPA (OPCPA) with short pulse pump lasers [8]. Latter uses self-induced plasma switches for the contrast enhancement, which were first demonstrated using glass substrates in 1991 [9] and later on using liquid jets in 1993 [10].

A Plasma Mirror (PM) system is based on the technique of self-induced plasma shuttering [9]. This technique ensures that the contrast of a high-intensity ultrashort laser pulse is enhanced. As a solid is ionized by the incident pulse, a highly over-dense plasma layer is formed, with a high reflectivity close to unity which is independent on the initial properties of the material.

In fig. 4 is presented a schematic single plasma mirror system. The incident ultrashort laser pulse is focused onto a glass substrate with an anti-reflection (AR) coating, chosen such that ionization is triggered only by the main pulse but not the

pre-pulse, which is transmitted through the sample. In this way only the main pulse will be reflected and the contrast will be enhanced.

It was found [11] that in order for the plasma mirror to function with an undistorted reflected pulse (that is to say, the reflection will be specular) the following condition must be met  $c_s \Delta t < \lambda_{laser}$ , where  $c_s$  is the sound speed and  $\Delta t$  is the time elapsed between the time of plasma formation and the peak of the pulse.

In terms of reflectivity, previous studies have shown [11,12] that there is an optimal intensity of around  $10^{16}$  W/cm<sup>2</sup> yielding a reflectivity higher than 65% without changing the spatial quality of the beam.

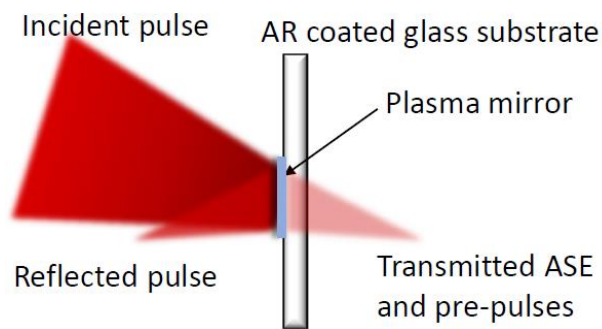

Fig. 4 – Schematic view of a single plasma mirror setup.

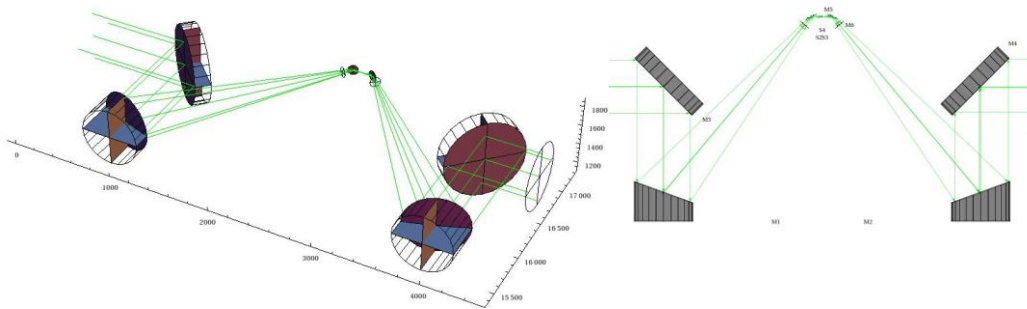

Fig. 5 – Double PM system

In fig. 5 a double plasma mirror system ray-tracing is depicted. As two plasma mirrors are used, the contrast enhancement is larger than two orders of magnitude, corresponding to at least one order of magnitude for each plasma mirror. The main disadvantage of this typical double plasma mirror approach is

related to the dimension of the optics and of the beam, if the 10PW beams are considered which have a full aperture diameter of 550 mm. The beam can be easily become obstructed or clipped by the mirror mounts. Also, if the plasma mirror is set up to have a large incidence angle, it will be sensitive to laser polarization. Close to normal incidence in the plasma mirror production is significantly less sensitive to the polarization than larger angle deflection.

An alternative approach that can overcome some of these issues is depicted below (fig. 6).

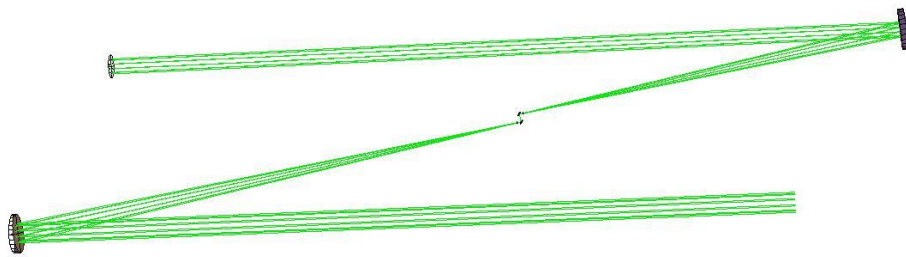

Fig. 6 – Alternative configuration of a PM system.

This system also implements two plasma mirrors, as shown in the fig. 7.

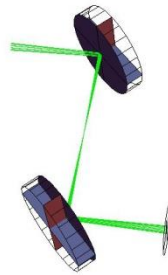

Fig. 7 – Close-up view of the alternative plasma mirror configuration.

Main advantage of this approach is related to the use of the plasma mirrors can be made at smaller than 45 degree angles, making it less polarization sensitive. The position and the size of the laser spot on the plasma mirror impacts on the plasma mirrors manipulation system that has to be designed. The typical efficient implementation of plasma mirrors is made in the range of  $10^{15}$  W/cm<sup>2</sup>-  $10^{17}$  W/cm<sup>2</sup>

with higher intensity optimum at shorter pulses lengths (HPLS will deliver about 22 fs pulses). This corresponds to a diameter of the spot from  $\sim 3$  mm to  $\sim 3$  cm. As a consequence, implementation of (multilayer coated) dielectric plates will limit the repetition rate of the HPLS due to the large size of the beam. The realignment and movement of the plasma mirror after each shot will present technical challenges. As a solution, liquid surface for plasma mirror, or any further alternative self regenerating surface approach has to be implemented, provided that the quality of the surface is preserved. Support from the IZEST working group involved in this direction is expected and a local ELI-NP development in this direction is a must.

### 3.1.3. Polarization control

As presented in the ELI-NP White Book [13] and also in [14, 15] circular polarization is needed in the recently described acceleration mechanism Radiation Pressure Acceleration (RPA). When a few-nanometer-thick foil is irradiated by circularly polarized high intensity laser pulse, a cold compression of electron sheet is realized, followed by the acceleration of ions in the rectified dipole field created between electrons and ions. In this way, macroscopically neutral bunches of ions and electrons traveling at the same speed are created. This RPA mechanism is predicted to be more efficient than target normal sheet acceleration (TNSA) mechanism and to scale linearly with the laser intensity. At laser intensities of  $10^{24}$  W/cm<sup>2</sup> and higher, the H and He nuclei are expected to enter the relativistic regime, when they will be accelerated directly by the laser, similar to the electrons at laser intensities greater than  $10^{18}$  W/cm<sup>2</sup>. The electron energies obtained in the present are up to several hundreds of MeV, while for heavy ions are about several MeV/nucleon and are expected to increase with one-two orders of magnitude at 10 PW,  $10^{24}$  W/cm<sup>2</sup> lasers.

Two of the experiments proposed to be performed at the ELI-NP facility, namely the Laser driven Nuclear Physics (area E1) and Laser High Fields and QED (area E6) needs the circular polarization of the laser beam in order to accelerate heavy ions.

Circularly polarized laser beams of high homogeneity are required for many applications for example in Compton polarimetry. When applied in laser-particle acceleration, circularly polarized lasers can significantly reduce the production of hot electrons and the associated high energetic radiation [16].

In the majority of experiments, circularly polarized light is created using a quarter-wave-plate made of mica, quartz glass or other crystalline material. This technique cannot be easily applied in ultra-high intensity short-pulse lasers due to nonlinear effects, the low damage threshold of the material, and the fact that ultra-thin wave-plates have a chromaticity that prevents their usage for broadband laser sources [17].

In [16-18], advances have been made in designing a phase shifting mirror that uses an all-reflective polarization rotation approach to implement the circular polarization for high intensity short-pulse laser experiments. In [18], the technique uses multiple coated mirrors, each with an aperture of  $120 \times 160 \text{ mm}^2$  supporting a beam diameter of 100 mm with a spectral range of  $800 \pm 40 \text{ nm}$  where the assembly is rotated to 45 degrees to provide equal s and p polarization field components.

The main techniques and tools used to implement the circular polarization are quarter-wave-plate made of mica, multiple coated dielectric mirrors in a setup that is rotated at a specific angle to provide equal field components for s and p polarization and designed to provide a phase shift of 90 degrees or reflective surfaces with different phase shift for s and p polarizations.

The aspects that must be taken into account in the particular case of ELI-NP are: the large laser beam diameter requires large aperture mirrors, the large spectral bandwidth and high damage threshold of the mirrors. Due to the large bandwidth of the ELI-NP Ti-Sa laser (larger than 150 nm full spectral range), the spectral range of the available on-the-market dielectric mirrors may prove insufficient.

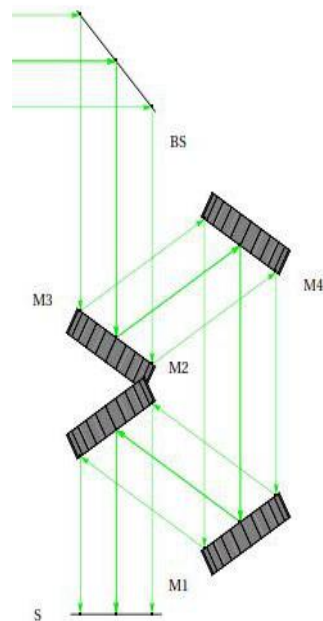

Fig. 8 – Polarization control using reflective optics.

The system used in PHELIX experiments looks as in fig. 8. The FSU Jena group would like to contribute to the polarization control of the amplified and compressed pulses. They propose to use fully reflective optics (which are scalable to large diameters) for this purpose in order to generate circular polarization and also 90 degree polarization rotation.

### 3.1.4. Adaptive optics

The main advantage of the short pulse duration lasers such as the one in ELI-NP is to obtain ultra-high intensity at the focal spot. The level of intensity is driven by the energy, the pulse duration and the surface of the focal spot. This means that the intensity has a quadratic dependence on the beam radius at focus. Spatial beam quality is therefore crucial. This means that the laser beam wavefront has to exhibit low values and must avoid as much as possible the presence of high spatial frequencies modulations.

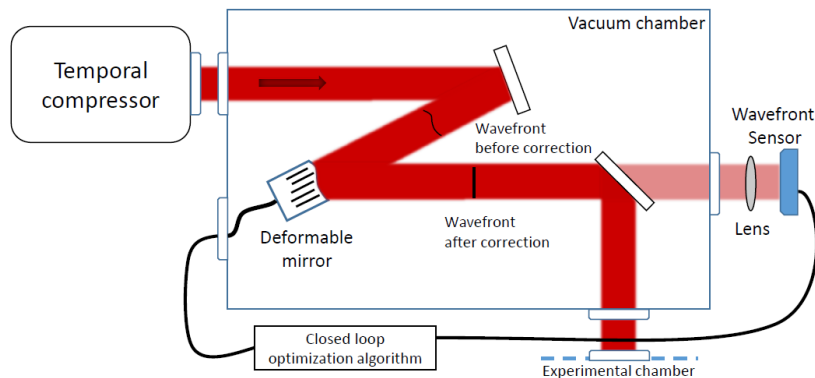

Fig. 9 – Reflective adaptive optics with an angle of incidence close to  $0^\circ$ , positioned after the compressor.

In smaller intense lasers systems, up to few hundreds of terawatt, this is already taken into account and the targeted final wavefront is obtained by the use of adaptive optics, *i.e.* some deformable mirrors (DM).

The standard configuration is shown on fig. 9. For these systems, different types of DM are available as the beam diameter is close to 10 cm but not all of them are relevant for achieving a low level of high spatial frequencies modulations. Indeed, piezo-electric based DMs are very often generating high spatial frequencies modulations because of print-through effect. The actuator's structure can be seen through the substrate. The problem is coming from the design of the DM itself. The

thickness of the substrate of the mirror is very often very small, in order to achieve correction travel range of many tens of  $\mu\text{m}$ . This is required when used in astronomy but this range can be decreased for use in lasers. By thinking so, the thickness is increased which leads to lower print-through effect.

The solutions that have been implemented on small lasers are based on piezoelectric actuation or mechanical actuation. The monomorph DM implement piezo-electrical plate (PZT plate) insulated for generating the electrodes while bimorph DM have two PZT plates that deform the substrate of the mirror. The DM with mechanical type actuators have a removable plate acting as the mirror surface which is deformed by the use of mechanical translation stages and springs actuators. These three solutions are allowing to achieve more than 70% of the energy in the focal spot and a Strehl ratio larger than 80%

For the 10 PW laser beam on ELI-NP, specific aspects have to be considered. The beam propagation distances are long ( $\sim 60$  meters) so the print-through effect of the actuators on the DM has to be very low. Simulations have to be done to quantify this level. The beam is 55 cm in diameter and currently, DM having the corresponding useful aperture size are not existing. Nevertheless, PZT mirrors were already manufactured to intermediate sizes and also the mechanical type DM are scalable. A study will have to be done for ensuring that this solution is possible. The pulse duration is very short: the coating of the mirror has to provide the spectral bandwidth without perturbing the temporal pulse profile and without being affected by the mirrors deformations.

The shape of the deformable mirror surface has to be measured in order to control the associated wavefront. This is done in standard manner by using a wavefront sensor positioned after the DM. This tool is an imaging plane of the DM in order to shape correctly the DM in a single process. For ELI-NP beams, this solution is implantable with an effort on the optical system that will relay image the DM. This optical system has to be achromatic as the pulse duration is short.

In the configuration of the ELI-NP scheme, it can be interesting to also have a measure of the wavefront in the focal plane at the center of the target chamber. A solution will be to use the phase diversity method which seems to be promising but which has never been implanted yet in a femtosecond laser.

### 3.1.5 Back reflection isolation

The back reflection isolation is an essential issue, related to the very existence of the HPLS amplification chain. Back reflections of the laser beam might back-propagate, amplify in the Ti:Sapphire crystals due to the residual population inversion, and then destroy the laser components in the amplification chain. The sources of back-reflections are the solid targets at close to normal incidence and nonlinear processes in plasmas.



In general, the solid targets are very efficient back reflectors. If a plane target is used before the focus, the focusing system for the pulse will behave for the back-reflected pulse as a focusing element. Damage on the mirrors in the beam transportation chain can then be easily produced.

The nonlinear processes in plasma, such as Brillouin back-scattering, represent also a potential danger for the integrity of the laser system. However, they work efficiently for typical a narrow spectral bandwidth. As ELI-NP HPLS pulses are ultra-broadband (22 fs pulse duration corresponding to more than 50nm of bandwidth), very low level of back-reflection is expected due to such processes.

For small beam diameters, optical isolators can be used in the laser amplification chains. Also, polarization rotators in conjunction with Pockels cells are also suppressing back-reflection. For larger beam diameter such methods cannot be used. A possible approach to this problem is related to the implementation of plasma mirror as optical isolator in the LBD chain. The plasma generated during the propagation towards the target is efficiently reflecting the pulse only for a small temporal window, of the order of 5 ps, maybe less. After such interval, plasma expands and cools. As a consequence, it behaves as a diverging mirror and it also becomes an efficient absorber for the back reflected pulses. This can completely suppress the back-reflection of the pulses.

For ELI-NP, the use of plasma mirror as back-reflection isolator is proposed. Tests have to be performed on the lifetime of the plasma and the temporal interval where the plasma works efficiently as optical isolator.

### 3.1.6 Focusing optics

Focusing optics is determined by the TDRs requests. Typically, short focal distances are requested for interaction with solid targets. Long focal distances are requested when gaseous targets are used.

A guide on the achievable laser intensity is presented in reference [19]. The results covering larger f-numbers (approximately the focal distance divided by the laser beam diameter) of the mirrors are depicted in fig. 10. For f-number of about 3, corresponding to some of short focal distance parabolic mirrors planned for ELI-NP at E1 and E6, one can get  $10^{23}$  W/cm<sup>2</sup> for an ideal 10PW Gaussian beam.

For f-number of about 20, as planned for E6, the intensity is lower, of  $2 \cdot 10^{21}$  W/cm<sup>2</sup> for an ideal 10PW Gaussian beam, with the advantage of a longer confocal region as needed for experiments with sub-critical density targets.

In the case of sub-aperture beam corresponding to f-number 80 proposed at E6, the Intensity drops again a couple of orders of magnitude, to the  $10^{19}$  W/cm<sup>2</sup> range for an ideal 10 PW Gaussian beam.

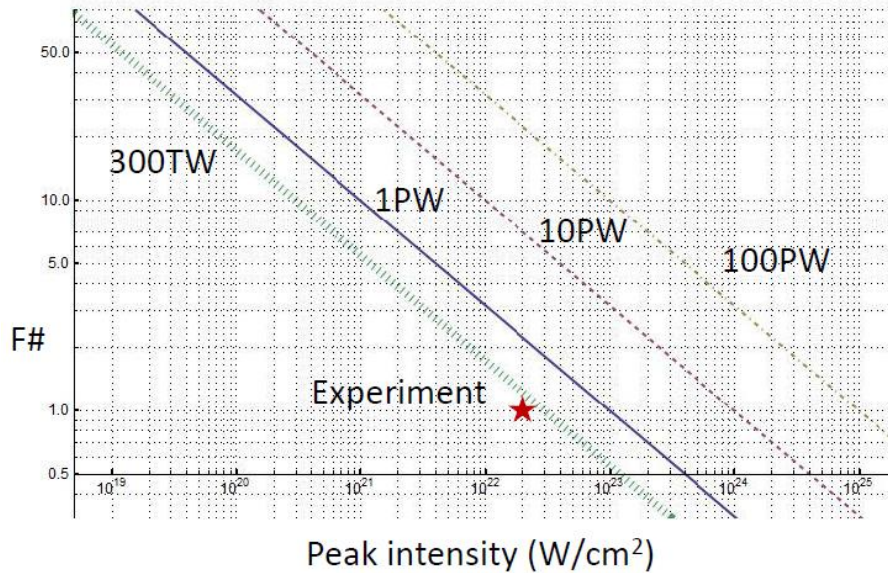

Fig. 10 – Peak intensity obtained by tightly focusing high power laser beams.

### 3.1.7 Technologies for 0.1 PW and for 1 PW

In the case of high repetition rate outputs, the technologies to be considered are pointed out below.

The relay imaging technology is implemented for preserving the beam pointing of the laser over the distance of beam transport line. For the 0.1 PW and 1 PW outputs, THALES Optronique SA is in charge with the transport system. As a consequence, they will have to provide the contractual beam pointing stability. The implementation of relay imaging systems on beam transport lines will help to produce the desired values of the beam pointing and beam quality after propagation to the experimental areas E4 and E5.

Plasma mirror technology is implemented in high power lasers for increasing the pulse contrast. From our experience with CETAL-PW laser produced by THALES, the company is able to provide a high pulse contrast. Nevertheless the implementation of plasma mirror will be a huge benefit for the improvement of the pulse contrast at ELI-NP facility. This technology could be demonstrated and tested at CETAL-PW facility previously to its implementation at ELI-NP. We consider that plasma mirror technology should be implemented on at least one of the ELI-NP PW laser beam lines.

The polarization control of the laser is important for the fundamental physical processes induced on the target. Due to the extreme powers involved in this facility, the polarization control is far from being a trivial problem. Special

reflective optics is necessary to be used for an effective polarization control. The all reflective system proposed by FSU Jena group could be implemented and tested at CETAL-PW facility in the 0.1 PW and 1 PW regime, with scalability possibilities for the 10 PW regimes. In the final ELI-NP facility, we consider that at least one of the 0.1 PW and one of the 1PW beam lines should have a polarization control system implemented.

Using adaptive optics technology is of special interest for the quality of the beam focusing. The adaptive optics will correct the beam wavefront distortions and will strongly increase its Strehl ratio. For example in the CETAL-PW facility adaptive optics was implemented to obtain a Strehl ratio larger than 0.75 (1 is the maximum value). Our experience with the CETAL-PW laser shows that adaptive optics is necessary to be implemented to obtain a good quality of the focus. Our opinion is that adaptive optics should be implemented in the amplification chain on all the beam lines of HPLS laser. Turnkey solutions are available [20, 21].

Back reflection isolators are implemented in laser systems to stop a reflected beam to enter the critical parts of the system, avoiding its damage. In a system so complex as a PW laser many back reflection isolators are already implemented by its producer to counteract the reflections produced by the system components. Nevertheless the protection of the entire system from the reflections produced in the interaction chambers are not usually considered by the laser producer. In our case we consider that the long propagation distance in the laser beam lines will prevent the entry of a reflected beam from the experimental room into the laser system. More calculations/simulations have to be done, on a near to final beam line design, to be sure that the previous statement is completely true.

For the focusing optics, off axis parabolas are the typical choice. These mirrors are specifically calculated to provide the best focusing quality at the desired incident angle. High power laser facilities are typically using short focal distance mirrors for particle acceleration experiments and long distance focusing mirrors for harmonic generations. For the ELI-NP facility, we propose that one of the 0.1 PW and one of the 1 PW arms to use a short focal parabolic mirror and the other one to use a long one. In this way both types of experiments can be performed. On the acquisition of the focusing optics one should take into account the time needed for the realization of this type of parabolic mirrors, up to half a year.

### 3.2. ADDITIONAL SHORT PULSES

The request for additional short pulse was formulated by the participants at ELI-NP related workshops.

Such short pulse might have various specifications, depending on their use. In general, one specific request is related to the presence of short pulses, in the 6 fs range, for probing the sub-critical density plasma density at the target with high

temporal resolution. The requested energy for such pulses lies in the few mJ range. The Jena group is interested to share their solution with ELI-NP.

The spare front-end might be also able to provide short pulses to probe plasma conditions. The estimated pulse duration of the front-end is in the 17fs range and the energy around 10 mJ. This approach requires oscillator's synchronization with the accuracy requested by the experiments.

Further short pulses with durations in the 22 fs range can be directly provided by HPLS, with energies of 2 J (100 TW outputs) and above (20 J, PW outputs).

### 3.3. ADDITIONAL LONG PULSE

Additional long pulse was requested in conjunction with experiments at E1.

Within HPLS contract discussions, provisions for space in order to extract such long laser pulses before compressors entrance were made. Further specifications from the TDRs are needed in order to proceed. The transport of such pulses to target areas remains an issue.

A possible method to achieve long pulses with full energy is by-passing the optical compressor. Alternatively, one can consider to remove two of the gratings in the compressor. Last, but not least, one can consider to replace the optical stretcher with an optical compressor, reducing the risk to damage the gratings and the re-alignment delays involved by the previous option.

### 3.4. SYNCHRONIZATION OF THE LASER PULSES WITH THE EXPERIMENTS

Synchronization of the laser pulses with the GBS and with the experiments will be realized using the frequency stable master clock to be acquired for the ELI-NP facility, and noise free synchronization signals from the laser front-end distributed in the facility through fiber based optical links. Such distribution systems, including reference clocks, are commercially available. In addition, electronic signal distribution to the experimental areas has to be provided with ns resolution, in order to fulfil experiments trigger needs. Delay generators have to be installed at the laser front-end level for this purpose. The stability of the lasers implemented in the ELI-NP front-end correspond to a synchronization jitter smaller than 200 fs.

### 3.5. PULSE QUALITY MANAGEMENT

#### 3.5.1. In-chain multiple laser pulses production

Several methods can be used in order to produce multiple pulse generation in the amplification chain. Two of them are described in [22] and [23]. A further

method is described in [24]. Such methods are bringing versatility to the facility. At ELI-NP, it is intended to apply both methods mentioned here. For the first one, a redesign of the stretcher is intended, in connection also with the long pulse generation requested (see section 3.3). This redesign would solve both the long pulse and multiple pulse production requirements, at least for one arm.

### 3.5.2. Laser pulses diagnostics on target

The knowledge of the experimental conditions on target is of prime importance for the users in a sense that they will be more confident for cross-checking the experimental results to the simulation. The relevant characteristic for the users is the intensity. But the direct knowledge of this one is very uncertain. The characteristics that have to be measured are the pulse energy, the pulse duration, the beam shape and size.

For the femtosecond laser pulses, the measurement of these parameters is classically done in the so-called mid-field, *i.e.* after the compression and not during the experimental shot. The measurements are obtained by inserting a sampling mirror on the path of the beam. The laser amplifiers are running at full energy and attenuation is done before compression to achieve the right energy for the measurement tools.

For an user facility such as ELI-NP, knowledge of the pulse parameters at full energy on target is somehow mandatory. The measurement is not possible in a direct way. It will be necessary to do it in several steps including measurement of the pulse duration and energy after the compressor, measurement of the focal spot in the plane of the target and the energy transmission from the output of the compressor to the target plane.

A rough measurement of the pulse duration and energy can be obtained after the compressor, at full energy, by using a leaking mirror with 1 % transmission. The beam is therefore decreased to the optimal size compatible with the temporal measurement tool. The down-collimating system will have to be in vacuum and will have to use achromatic optics components to avoid adding some temporal perturbations. The straightforward solution is again to use off-axis parabola. Converging-converging or converging-diverging configuration can be used to down-collimate. They have both advantages and drawbacks. A study on the impacts of both configurations has to be done for the ELI-NP configuration.

Given the beam size and the pulse duration on the infrastructure, the pulse duration has to be spatially resolved and needs also to have the capability to measure the group delay within the beam. Measurement tools that can do are only available on a laboratory development such as the “star-fish”, for example. This means that an evaluation of the different techniques has to be done to determine the appropriate one.

For the energy measurement, straightforward products are available in large size, up to 40 cm. Gentec-EO, for example, is providing joule meter for laser such as NIF in the USA and LMJ in France that can sustain high energy level fully compatible with the 10 PW beam lines. Therefore the two types of measurements that will allow obtaining the energy on-shot can be done. The methodology will be set in different steps that will allow the calibration of the line taking into account the energy loss from the compressor output to the target plane.

The focal spot measurement, which is mandatory for intensity quantification, is nowadays not possible on-shot. The main obstacle is the sampling of the pulse without modifying it. Therefore this measurement can be done directly in the focal plane at low energy compatible with the measurement tool. The energy attenuation will be implemented before compression.

The low energy measurement is obtained with a high dynamic range CCD, ideally 16 bits, and a microscope objective to increase the resolution. The numerical analysis of the focal spot will give the amount of encircled energy which will be the input for the calculation of the intensity.

Another relevant number to quantify is the temporal contrast ratio on a time window from few picoseconds to few hundreds of picoseconds on a dynamic range of 12 to 14 orders of magnitude. This value is very critical for knowing what will be the interaction conditions especially for thin target. For measuring this contrast, on high repetition rate systems (10 Hz), there are already third order cross-correlator. For 10 PW one shot per minute pulses, these tools are not relevant because of the very large acquisition time that would be required. Indeed for ensuring a high fidelity measurement, averaging on 100 shots for each time step on 1000 steps is required which lead to hours and hours time of measurement. This is not realistic.

A single-shot contrast measurement tool does not exist. Few institutes world-wide, have also this need. Collaboration with one or more of these institutes will have to be initiated.

### **3.5.3. Pulses synchronization and coherent combination**

As presented in “ELI-NP White Book”, the coherent combination of the high power ultrashort pulses from the parallel amplification chains is envisaged at ELI-NP, in order to reach intensities of the order of  $10^{23}$  W/cm<sup>2</sup> and above. The operation of the experiments will take place in parallel, the laser pulses being delivered to different experimental areas on request. By amplification in Ti:sapphire, the predicted peak power that could be reached before year 2020 is limited at about 10 PW by the size of achievable crystals. Next scaling would be possible only by coherent beam combination of several 10 PW Ti:sapphire femtosecond lasers.

Coherent beam combining (CBC) of multiple ultra-short laser beams represents an effective solution to obtain a high power laser for both continuous wave and pulsed systems. CBC method has been demonstrated with diode, solid-state, fiber, and gas lasers, but current efforts focus on fiber lasers and diode in continuous regime. Up to now, little work is related to pulsed lasers in the ns range and below. The coherent beam combination technique is often used in continuous wave laser systems [25, 26], in pulsed laser systems with nanosecond long pulses [27, 28], also in optical parametric amplifiers [29], in short pulse fiber laser systems [30-32] and also for two separate femtosecond lasers [33]. However, in order to scale the intensities of ultra-short pulse lasers in the femtosecond domain such CBC technique is needed.

The coherent beam combining technique requires that the sources are coherent and relative phases of combined beams are precisely controlled to a small fraction of the wavelength. The main difficulty is to obtain phase coherence at high power levels in a sufficiently stable manner, working not only in a quiet laboratory environment but also in a mechanically more noisy industrial setting. Another challenge is the need to match precisely and stably, wavefronts and polarization directions.

One way to coherently combine the ultrashort pulses is to take several identical ultrashort pulses and overlap them directly on the target. Up to now, no experimental report exists concerning this approach. However, if this works, there might be an alternative better solution that would allow to obtain significant power increase on the target, by using laser pulses with complementing spectral composition.

One important issue in CBC relates to the mechanical stability of the entire laser amplification chain and to the possibility to measure and control the specific displacements. This might increase the cost of the mechanical components along the amplification path a factor of 2 or 3. Related interferometric methods for optical path stabilization were developed in INFLPR, within LASERLAB2 European project.

The final step to be performed in order to have a fully scalable parallelization method is to demonstrate coherent combination of pulses generated in the same system and then further amplified in two distinct amplifiers.

In order to achieve the coherent beam combination, the different sources of fluctuations of the electric field have to be estimated. These fluctuations are the gain fluctuation in the two amplifiers that generate different Atomic Phase Shift (APS), the optical path that can be different due to vibrations considerations, thermal aspects in the amplifiers media, air fluctuations. This is especially difficult due to the optical path length (OPL) fluctuations experienced by the pulses along the amplification process, dynamically induced on microsecond short time scales by the pumping of the laser amplifiers.

Optical parametric amplifiers and fiber lasers are an attractive choice for CBC because no thermal effects appear. In fiber lasers, the pulse doesn't experience phase shift due to vibrations or air fluctuations. In the 10 PW Ti:Sa laser case, these aspects must however be taken into account as the above mentioned technologies are not found in the final stages of the ELI-NP amplification chain.

The main techniques and tools used to implement the Coherent Beam Combination are interferometric phase measurement devices of the two beams, piezo-mounted mirror set to achieve a fine correction of the path length mismatch of the order of at least several wavelengths coupled to the corresponding feedback control loop, including logic and electronics, and the recombination techniques: mirrors and gratings [23], polarizing beam splitters, etc.

Spatial light modulators, acousto-optic modulators or electro-optic modulators cannot be used in the final stages of ELI-NP HPLS due to the high power of the laser and dimensions.

Several aspects must be taken into account in the particular case of ELI-NP, as discussed here further. Vibrations appear in the long optical chains. It was found in [34] that in a coherent pulse synthesis setup that uses a femtosecond laser and an optical parametric oscillator, a likely source of perturbation was the acousto-mechanical noise generated by a fan from the laser driver unit. Thermal effects appear in Ti:Sa amplifiers. The thermal effects will be amplified in the ELI-NP case because of the increased size of the Ti:Sa crystal. The optical path lengths on the two branches have to be matched with sub-wavelength precision. The pulses have to be identical for the two channels: spectral amplitude and phase, spatial intensity profile and spatial phase. Finally, perfect overlap of the pulses is necessary in the near and far field, in order to obtain a combined output not to be distinguishable from a single emission [32].

The specific tools needed to implement Coherent Beam Combination at ELI-NP are a test setup for the coherent combining of two amplifiers, real time interferometers for monitoring of optical path fluctuations in the amplification modules of the HPLS, phase shift measurement methods for two parallel amplification chains and further diagnostics tools and various types of actuators, that can compensate the optical phase shift at short time scales (acoustic waves) and at long time scale (mechanical drift of the mounts).

#### **3.5.4. Laser beam dumps, shutters and energy attenuation**

Energy control is an important aspect of the pulse quality management, as the experiments typically require the pulse energy control. This has to be made in reflection, using wedged glass plates, taking into account the Fresnel specular reflectivity.

The distribution of the HPLS pulses to the different outputs is provided through HPLS system.



For each of the laser-target interaction places, laser beam dump has to be provided. Such a beam dump can be based on absorbing glass plates. For high repetition rate outputs, cooling of such plates shall be implemented. The same might be valid for the absorbing glass plates that have to be placed in vacuum for the 10PW pulses.

Shutters for large laser beam diameters are generally slow. So the implementation of the shutters shall be realized in the HPLS amplification chains, as up-stream as possible.

The pulse energy control in laser systems is often based on combinations of wave-plates and polarization-sensitive beam splitters. Such optical components are not easily available in large dimensions and in good quality. As seen in [16-18], reflective circular polarization devices have been implemented, but, similar to the transmission optics case, these devices are also not easily available due to their dimensions. As a consequence, alternative path has to be looked after. One option would be to use mirrors with partially reflective coatings that might be available in large dimensions. A second option would be to tweak the pumping power of the pump lasers in the amplification chain. A third option is related to the attenuation of the seed pulse in the amplification chains. The last two approaches have as disadvantage the generation of laser pulse energy fluctuations, as the amplifiers might not run in saturation.

#### 4. CONCLUSION

The Technical Design Report for Laser Beam Delivery summarizes main aspects of the technologies to be considered for a proper implementation of the interface between the HPLS and the experiments at ELI-NP. These research and development subjects are part of a very dynamic field of studies. Hence, better ways of doing the beam transport of ultrashort laser pulses are already under development and they shall be implemented whenever they offer significant advantages over the existing technologies discussed here.

**Acknowledgements.** D. Ursescu, R. Dabu, M. O. Cernaianu, I. Dancus, L. Neagu, T. Asavei and A. Boianu were supported by the Project Extreme Light Infrastructure - Nuclear Physics (ELI-NP) - Phase I, a project co-financed by the Romanian Government and European Union through the European Regional Development Fund.

#### REFERENCES

1. F. Negoita *et al.*, Romanian Reports in Physics **68**, S37 (2016)
2. E. Turcu, *et al.*, Romanian Reports in Physics **68**, S145 (2016)
3. K. Homma *et al.*, Romanian Reports in Physics **68**, S233 (2016)
4. T. Asavei *et al.*, Romanian Reports in Physics **68**, S275 (2016)

5. M. Cernaianu *et al.*, Romanian Reports in Physics **68**, S349 (2016)
6. M. Kalashnikov *et al.*, Optics Express **12**, 5088, (2004).
7. A. Jullien *et al.*, Optics Letters **30**, 920, (2005).
8. A. Duniatis *et al.*, Optics Comm. **88**, 437 (1992).
9. H. C. Kapteyn *et al.*, Optics Letters **16**, 490 (1991).
10. S. Backus *et al.*, Optics Letters **18**, 134 (1993).
11. B. Dromey, S. Kar, M. Zepf, and P. Foster, Review of Scientific Instruments **75**, 645 (2004).
12. Ch. Ziener *et al.*, Journal of Applied Physics **93**, 768 (2003).
13. ELI-NP White Book, <http://www.eli-np.ro> (2011)
14. A. Macchi *et al.*, New Journal of Physics **12**, 045013 (2010)
15. B. Qiao *et al.*, Phys. Rev. Lett. **105**, 155002 (2010)
16. B. Aurand *et al.*, Optics Express **19**, 17151 (2011)
17. S. Keppler *et al.*, Optics Express **20**, 20742 (2012)
18. B. Aurand *et al.*, Review of Scientific Instruments **83**, 036104 (2012)
19. L. Ionel, D. Ursescu, Laser and Particle Beams **32**, 89 (2014)
20. <http://www.lasqua.fr/anglais.htm> , as in November (2015)
21. <http://www.imagine-optic.com/en/applications/adaptive-optics/> , as in November (2015)
22. D. Ursescu *et al.*, J. Optoelectron. Adv. Matter. **12**, 100 (2010)
23. R. Banici, D. Ursescu, EPL **94**, 44002 (2011).
24. G. Cojocaru *et al.*, Optics Letters **39**, 2246 (2014)
25. G. D Goodno, *et al.*, Optics Letters **31**, 1247 (2006).
26. B. Chann *et al.*, Optics Letters **30**, 2104 (2005).
27. H. J. Kong *et al.*, Laser and Particle Beams, **27**, 179184 (2009).
28. J. S Shin *et al.*, Applied Physics Letters **96**, 131116 (2010).
29. T. Kurita *et al.*, Optics Express **18**, 14541 (2010).
30. G. Krauss *et al.*, Nat. Photon. **4**, 33 (2010)
31. M. Daniault *et al.*, Optics Letters **36**, 621 (2011)
32. E. Seise, A. Klenke, J. Limpert, A. Tünnemann, Optics Express **18**, 27829 (2010)
33. R. K. Shelton *et al.*, Science **293**, 1286 (2001)
34. B. J. S. Gale, J.H. Sun, D.T. Reid, Optics Express **16**, 1616 (2008).